



power contactor, AC-3e/AC-3, 9 A, 4 kW / 400 V, 3-pole, 230 V AC, 50/60 Hz, auxiliary contacts: 1 NO, screw terminal, size: S00

<b>product brand name</b>	SIRIUS
<b>product designation</b>	Power contactor
<b>product type designation</b>	3RT2
<b>General technical data</b>	
<b>size of contactor</b>	S00
<b>product extension</b>	
• function module for communication	No
• auxiliary switch	Yes
<b>power loss [W] for rated value of the current</b>	
• at AC in hot operating state	0.9 W
• at AC in hot operating state per pole	0.3 W
• without load current share typical	1.1 W
<b>type of calculation of power loss depending on pole</b>	quadratic
<b>insulation voltage</b>	
• of main circuit with degree of pollution 3 rated value	690 V
• of auxiliary circuit with degree of pollution 3 rated value	690 V
<b>surge voltage resistance</b>	
• of main circuit rated value	6 kV
• of auxiliary circuit rated value	6 kV
maximum permissible voltage for protective separation between coil and main contacts according to EN 60947-1	400 V
<b>shock resistance at rectangular impulse</b>	
• at AC	6,7g / 5 ms, 4,2g / 10 ms
<b>shock resistance with sine pulse</b>	
• at AC	10,5g / 5 ms, 6,6g / 10 ms
<b>mechanical service life (operating cycles)</b>	
• of contactor typical	30 000 000
• of the contactor with added electronically optimized auxiliary switch block typical	5 000 000
• of the contactor with added auxiliary switch block typical	10 000 000
<b>reference code according to IEC 81346-2</b>	Q
<b>Substance Prohibitance (Date)</b>	10/01/2009
<b>Net Weight</b>	229 g
<b>Ambient conditions</b>	
installation altitude at height above sea level maximum	2 000 m
<b>ambient temperature</b>	
• during operation	-25 ... +60 °C
• during storage	-55 ... +80 °C
<b>relative humidity minimum</b>	10 %
<b>relative humidity at 55 °C according to IEC 60068-2-30</b>	95 %

<b>maximum</b>	
<b>Environmental footprint</b>	
Environmental Product Declaration(EPD)	Yes
global warming potential [CO2 eq] total	39.6 kg
global warming potential [CO2 eq] during manufacturing	1.18 kg
global warming potential [CO2 eq] during operation	38.5 kg
global warming potential [CO2 eq] after end of life	-0.155 kg
<b>Main circuit</b>	
<b>number of poles for main current circuit</b>	3
<b>number of NO contacts for main contacts</b>	3
<b>number of NC contacts for main contacts</b>	0
<b>operating voltage</b>	
• at AC-3 rated value maximum	690 V
• at AC-3e rated value maximum	690 V
<b>operational current</b>	
• at AC-1 at 400 V at ambient temperature 40 °C rated value	22 A
• at AC-1	
— up to 690 V at ambient temperature 40 °C rated value	22 A
— up to 690 V at ambient temperature 60 °C rated value	20 A
• at AC-3	
— at 400 V rated value	9 A
— at 500 V rated value	7.7 A
— at 690 V rated value	6.7 A
• at AC-3e	
— at 400 V rated value	9 A
— at 500 V rated value	7.7 A
— at 690 V rated value	6.7 A
• at AC-4 at 400 V rated value	8.5 A
• at AC-5a up to 690 V rated value	19.4 A
• at AC-5b up to 400 V rated value	7.4 A
• at AC-6a	
— up to 230 V for current peak value n=20 rated value	5.3 A
— up to 400 V for current peak value n=20 rated value	5.3 A
— up to 500 V for current peak value n=20 rated value	5.3 A
— up to 690 V for current peak value n=20 rated value	5 A
• at AC-6a	
— up to 230 V for current peak value n=30 rated value	3.5 A
— up to 400 V for current peak value n=30 rated value	3.5 A
— up to 500 V for current peak value n=30 rated value	3.6 A
— up to 690 V for current peak value n=30 rated value	3.3 A
minimum cross-section in main circuit at maximum AC-1 rated value	4 mm <sup>2</sup>
<b>operational current for approx. 200000 operating cycles at AC-4</b>	
• at 400 V rated value	4.1 A
• at 690 V rated value	3.3 A
<b>operational current</b>	
• <b>at 1 current path at DC-1</b>	
— at 24 V rated value	20 A
— at 60 V rated value	20 A
— at 110 V rated value	2.1 A
— at 220 V rated value	0.8 A
— at 440 V rated value	0.6 A
— at 600 V rated value	0.6 A
• <b>with 2 current paths in series at DC-1</b>	
— at 24 V rated value	20 A
— at 60 V rated value	20 A

<ul style="list-style-type: none"> <li>— at 110 V rated value</li> <li>— at 220 V rated value</li> <li>— at 440 V rated value</li> <li>— at 600 V rated value</li> </ul>	12 A 1.6 A 0.8 A 0.7 A
<ul style="list-style-type: none"> <li>● <b>with 3 current paths in series at DC-1</b> <ul style="list-style-type: none"> <li>— at 24 V rated value</li> <li>— at 60 V rated value</li> <li>— at 110 V rated value</li> <li>— at 220 V rated value</li> <li>— at 440 V rated value</li> <li>— at 600 V rated value</li> </ul> </li> </ul>	20 A 20 A 20 A 20 A 1.3 A 1 A
<ul style="list-style-type: none"> <li>● <b>at 1 current path at DC-3 at DC-5</b> <ul style="list-style-type: none"> <li>— at 24 V rated value</li> <li>— at 60 V rated value</li> <li>— at 110 V rated value</li> </ul> </li> </ul>	20 A 0.5 A 0.15 A
<ul style="list-style-type: none"> <li>● <b>with 2 current paths in series at DC-3 at DC-5</b> <ul style="list-style-type: none"> <li>— at 24 V rated value</li> <li>— at 60 V rated value</li> <li>— at 110 V rated value</li> </ul> </li> </ul>	20 A 5 A 0.35 A
<ul style="list-style-type: none"> <li>● <b>with 3 current paths in series at DC-3 at DC-5</b> <ul style="list-style-type: none"> <li>— at 24 V rated value</li> <li>— at 60 V rated value</li> <li>— at 110 V rated value</li> <li>— at 220 V rated value</li> <li>— at 440 V rated value</li> <li>— at 600 V rated value</li> </ul> </li> </ul>	20 A 20 A 20 A 1.5 A 0.2 A 0.2 A
<b>operating power</b> <ul style="list-style-type: none"> <li>● at AC-3               <ul style="list-style-type: none"> <li>— at 230 V rated value</li> <li>— at 400 V rated value</li> <li>— at 500 V rated value</li> <li>— at 690 V rated value</li> </ul> </li> <li>● at AC-3e               <ul style="list-style-type: none"> <li>— at 230 V rated value</li> <li>— at 400 V rated value</li> <li>— at 500 V rated value</li> <li>— at 690 V rated value</li> </ul> </li> </ul>	2.2 kW 4 kW 4 kW 5.5 kW  2.2 kW 4 kW 4 kW 5.5 kW
<b>operating power for approx. 200000 operating cycles at AC-4</b> <ul style="list-style-type: none"> <li>● at 400 V rated value</li> <li>● at 690 V rated value</li> </ul>	2 kW 2.5 kW
<b>operating apparent power at AC-6a</b> <ul style="list-style-type: none"> <li>● up to 230 V for current peak value n=20 rated value</li> <li>● up to 400 V for current peak value n=20 rated value</li> <li>● up to 500 V for current peak value n=20 rated value</li> <li>● up to 690 V for current peak value n=20 rated value</li> </ul>	2 kVA 3.6 kVA 4.6 kVA 5.9 kVA
<b>operating apparent power at AC-6a</b> <ul style="list-style-type: none"> <li>● up to 230 V for current peak value n=30 rated value</li> <li>● up to 400 V for current peak value n=30 rated value</li> <li>● up to 500 V for current peak value n=30 rated value</li> <li>● up to 690 V for current peak value n=30 rated value</li> </ul>	1.3 kVA 2.4 kVA 3.1 kVA 4 kVA
<b>short-time withstand current in cold operating state up to 40 °C</b> <ul style="list-style-type: none"> <li>● limited to 1 s switching at zero current maximum</li> <li>● limited to 5 s switching at zero current maximum</li> <li>● limited to 10 s switching at zero current maximum</li> <li>● limited to 30 s switching at zero current maximum</li> <li>● limited to 60 s switching at zero current maximum</li> </ul>	155 A; Use minimum cross-section acc. to AC-1 rated value 111 A; Use minimum cross-section acc. to AC-1 rated value 86 A; Use minimum cross-section acc. to AC-1 rated value 66 A; Use minimum cross-section acc. to AC-1 rated value 55 A; Use minimum cross-section acc. to AC-1 rated value
<b>no-load switching frequency</b>	

<ul style="list-style-type: none"> <li>• at AC</li> </ul>	10 000 1/h
<b>operating frequency</b>	
<ul style="list-style-type: none"> <li>• at AC-1 maximum</li> </ul>	1 000 1/h
<ul style="list-style-type: none"> <li>• at AC-2 maximum</li> </ul>	750 1/h
<ul style="list-style-type: none"> <li>• at AC-3 maximum</li> </ul>	750 1/h
<ul style="list-style-type: none"> <li>• at AC-3e <ul style="list-style-type: none"> <li>— maximum</li> </ul> </li> </ul>	750 1/h
<ul style="list-style-type: none"> <li>• at AC-4 maximum</li> </ul>	250 1/h

### Control circuit/ Control

<b>type of voltage of the control supply voltage</b>	AC
<b>control supply voltage at AC</b>	
<ul style="list-style-type: none"> <li>• at 50 Hz rated value</li> </ul>	230 V
<ul style="list-style-type: none"> <li>• at 60 Hz rated value</li> </ul>	230 V
<b>operating range factor control supply voltage rated value of magnet coil at AC</b>	
<ul style="list-style-type: none"> <li>• at 50 Hz</li> </ul>	0.8 ... 1.1
<ul style="list-style-type: none"> <li>• at 60 Hz</li> </ul>	0.85 ... 1.1
<b>apparent pick-up power of magnet coil at AC</b>	
<ul style="list-style-type: none"> <li>• at 50 Hz</li> </ul>	27 VA
<ul style="list-style-type: none"> <li>• at 60 Hz</li> </ul>	24.3 VA
<b>inductive power factor with closing power of the coil</b>	
<ul style="list-style-type: none"> <li>• at 50 Hz</li> </ul>	0.8
<ul style="list-style-type: none"> <li>• at 60 Hz</li> </ul>	0.75
<b>apparent holding power of magnet coil at AC</b>	
<ul style="list-style-type: none"> <li>• at 50 Hz</li> </ul>	4.2 VA
<ul style="list-style-type: none"> <li>• at 60 Hz</li> </ul>	3.3 VA
<b>inductive power factor with the holding power of the coil</b>	
<ul style="list-style-type: none"> <li>• at 50 Hz</li> </ul>	0.25
<ul style="list-style-type: none"> <li>• at 60 Hz</li> </ul>	0.25
<b>closing delay</b>	
<ul style="list-style-type: none"> <li>• at AC</li> </ul>	9 ... 35 ms
<b>opening delay</b>	
<ul style="list-style-type: none"> <li>• at AC</li> </ul>	4 ... 15 ms
<b>arcing time</b>	10 ... 15 ms
<b>control version of the switch operating mechanism</b>	Standard A1 - A2

### Auxiliary circuit

number of NC contacts for auxiliary contacts instantaneous contact	0
number of NO contacts for auxiliary contacts instantaneous contact	1
operational current at AC-12 maximum	10 A
<b>operational current at AC-15</b>	
<ul style="list-style-type: none"> <li>• at 230 V rated value</li> </ul>	10 A
<ul style="list-style-type: none"> <li>• at 400 V rated value</li> </ul>	3 A
<ul style="list-style-type: none"> <li>• at 500 V rated value</li> </ul>	2 A
<ul style="list-style-type: none"> <li>• at 690 V rated value</li> </ul>	1 A
<b>operational current at DC-12</b>	
<ul style="list-style-type: none"> <li>• at 24 V rated value</li> </ul>	10 A
<ul style="list-style-type: none"> <li>• at 48 V rated value</li> </ul>	6 A
<ul style="list-style-type: none"> <li>• at 60 V rated value</li> </ul>	6 A
<ul style="list-style-type: none"> <li>• at 110 V rated value</li> </ul>	3 A
<ul style="list-style-type: none"> <li>• at 125 V rated value</li> </ul>	2 A
<ul style="list-style-type: none"> <li>• at 220 V rated value</li> </ul>	1 A
<ul style="list-style-type: none"> <li>• at 600 V rated value</li> </ul>	0.15 A
<b>operational current at DC-13</b>	
<ul style="list-style-type: none"> <li>• at 24 V rated value</li> </ul>	10 A
<ul style="list-style-type: none"> <li>• at 48 V rated value</li> </ul>	2 A
<ul style="list-style-type: none"> <li>• at 60 V rated value</li> </ul>	2 A
<ul style="list-style-type: none"> <li>• at 110 V rated value</li> </ul>	1 A
<ul style="list-style-type: none"> <li>• at 125 V rated value</li> </ul>	0.9 A

<ul style="list-style-type: none"> <li>• at 220 V rated value</li> <li>• at 600 V rated value</li> </ul>	<p>0.3 A</p> <p>0.1 A</p>
<b>contact reliability of auxiliary contacts</b>	1 faulty switching per 100 million (17 V, 1 mA)
<b>UL/CSA ratings</b>	
<b>full-load current (FLA) for 3-phase AC motor</b>	
<ul style="list-style-type: none"> <li>• at 480 V rated value</li> <li>• at 600 V rated value</li> </ul>	<p>7.6 A</p> <p>9 A</p>
<b>yielded mechanical performance [hp]</b>	
<ul style="list-style-type: none"> <li>• for single-phase AC motor <ul style="list-style-type: none"> <li>— at 110/120 V rated value</li> <li>— at 230 V rated value</li> </ul> </li> <li>• for 3-phase AC motor <ul style="list-style-type: none"> <li>— at 200/208 V rated value</li> <li>— at 220/230 V rated value</li> <li>— at 460/480 V rated value</li> <li>— at 575/600 V rated value</li> </ul> </li> </ul>	<p>0.33 hp</p> <p>1 hp</p> <p>2 hp</p> <p>3 hp</p> <p>5 hp</p> <p>7.5 hp</p>
<b>contact rating of auxiliary contacts according to UL</b>	A600 / Q600
<b>Short-circuit protection</b>	
design of the miniature circuit breaker for short-circuit protection of the auxiliary circuit up to 230 V	C characteristic: 10 A; 0.4 kA
<b>design of the fuse link</b>	
<ul style="list-style-type: none"> <li>• for short-circuit protection of the main circuit <ul style="list-style-type: none"> <li>— with type of coordination 1 required</li> <li>— with type of coordination 2 required</li> </ul> </li> <li>• for short-circuit protection of the auxiliary switch required</li> </ul>	<p>gG: 35 A (690 V, 100 kA), aM: 20 A (690 V, 100 kA), BS88: 35 A (415 V, 80 kA)</p> <p>gG: 20 A (690 V, 100 kA), aM: 16 A (690 V, 100 kA), BS88: 20 A (415 V, 80 kA)</p> <p>gG: 10 A (500 V, 1 kA)</p>
<b>Installation/ mounting/ dimensions</b>	
<b>mounting position</b>	+/-180° rotation possible on vertical mounting surface; can be tilted forward and backward by +/- 22.5° on vertical mounting surface
fastening method side-by-side mounting	Yes
<b>fastening method</b>	screw and snap-on mounting onto 35 mm DIN rail according to DIN EN 60715
<b>height</b>	58 mm
<b>width</b>	45 mm
<b>depth</b>	73 mm
<b>required spacing</b>	
<ul style="list-style-type: none"> <li>• with side-by-side mounting <ul style="list-style-type: none"> <li>— forwards</li> <li>— upwards</li> <li>— downwards</li> <li>— at the side</li> </ul> </li> <li>• for grounded parts <ul style="list-style-type: none"> <li>— forwards</li> <li>— upwards</li> <li>— at the side</li> <li>— downwards</li> </ul> </li> <li>• for live parts <ul style="list-style-type: none"> <li>— forwards</li> <li>— upwards</li> <li>— downwards</li> <li>— at the side</li> </ul> </li> </ul>	<p>10 mm</p> <p>10 mm</p> <p>10 mm</p> <p>0 mm</p> <p>10 mm</p> <p>10 mm</p> <p>6 mm</p> <p>10 mm</p> <p>10 mm</p> <p>10 mm</p> <p>10 mm</p> <p>6 mm</p>
<b>Connections/ Terminals</b>	
<b>type of electrical connection</b>	
<ul style="list-style-type: none"> <li>• for main current circuit</li> <li>• for auxiliary and control circuit</li> <li>• at contactor for auxiliary contacts</li> <li>• of magnet coil</li> </ul>	<p>screw-type terminals</p> <p>screw-type terminals</p> <p>Screw-type terminals</p> <p>Screw-type terminals</p>
<b>type of connectable conductor cross-sections</b>	
<ul style="list-style-type: none"> <li>• for main contacts <ul style="list-style-type: none"> <li>— solid</li> <li>— solid or stranded</li> </ul> </li> </ul>	<p>2x (0.5 ... 1.5 mm<sup>2</sup>), 2x (0.75 ... 2.5 mm<sup>2</sup>), 2x 4 mm<sup>2</sup></p> <p>2x (0,5 ... 1,5 mm<sup>2</sup>), 2x (0,75 ... 2,5 mm<sup>2</sup>), 2x 4 mm<sup>2</sup></p>

— finely stranded with core end processing	2x (0.5 ... 1.5 mm <sup>2</sup> ), 2x (0.75 ... 2.5 mm <sup>2</sup> )
• for AWG cables for main contacts	2x (20 ... 16), 2x (18 ... 14), 2x 12
<b>connectable conductor cross-section for main contacts</b>	
• solid	0.5 ... 4 mm <sup>2</sup>
• stranded	0.5 ... 4 mm <sup>2</sup>
• finely stranded with core end processing	0.5 ... 2.5 mm <sup>2</sup>
<b>connectable conductor cross-section for auxiliary contacts</b>	
• solid or stranded	0.5 ... 4 mm <sup>2</sup>
• finely stranded with core end processing	0.5 ... 2.5 mm <sup>2</sup>
<b>type of connectable conductor cross-sections</b>	
• for auxiliary contacts	
— solid or stranded	2x (0.5 ... 1.5 mm <sup>2</sup> ), 2x (0.75 ... 2.5 mm <sup>2</sup> ), 2x 4 mm <sup>2</sup>
— finely stranded with core end processing	2x (0.5 ... 1.5 mm <sup>2</sup> ), 2x (0.75 ... 2.5 mm <sup>2</sup> )
• for AWG cables for auxiliary contacts	2x (20 ... 16), 2x (18 ... 14), 2x 12
<b>AWG number as coded connectable conductor cross section for main contacts</b>	20 ... 12
<b>AWG number as coded connectable conductor cross section for auxiliary contacts</b>	20 ... 12

### Safety related data

<b>product function</b>	
• mirror contact according to IEC 60947-4-1	Yes; with 3RH29
• positively driven operation according to IEC 60947-5-1	No
• suitable for safety function	Yes
suitability for use safety-related switching OFF	Yes
<b>service life maximum</b>	20 a
<b>test wear-related service life necessary</b>	Yes
<b>proportion of dangerous failures</b>	
• with low demand rate according to SN 31920	40 %
• with high demand rate according to SN 31920	73 %
<b>B10 value with high demand rate according to SN 31920</b>	1 000 000
<b>failure rate [FIT] with low demand rate according to SN 31920</b>	100 FIT

### ISO 13849

<b>device type according to ISO 13849-1</b>	3
<b>overdimensioning according to ISO 13849-2 necessary</b>	Yes

### IEC 61508

<b>safety device type according to IEC 61508-2</b>	Type A
--	--------

### Electrical Safety

<b>protection class IP on the front according to IEC 60529</b>	IP20
<b>touch protection on the front according to IEC 60529</b>	finger-safe, for vertical contact from the front

### Approvals Certificates

#### General Product Approval



[KC](#)

General Product Approval	EMV	Test Certificates	Maritime application
--------------------------	-----	-------------------	----------------------



[Type Test Certificates/Test Report](#)



[Special Test Certificate](#)



Maritime application	other
----------------------	-------



Miscellaneous

other	Railway	Environment
	<a href="#">Confirmation</a>	<a href="#">Confirmation</a>
	<a href="#">Special Test Certificate</a>	
		<a href="#">Environmental Confirmations</a>

Further information

Information on the packaging

<https://support.industry.siemens.com/cs/ww/en/view/109813875>

Information for data generation and storage

<https://support.industry.siemens.com/cs/ww/en/view/109995012>

Information- and Downloadcenter (Catalogs, Brochures,...)

<https://www.siemens.com/ic10>

Industry Mall (Online ordering system)

<https://mall.industry.siemens.com/mall/en/en/Catalog/product?mlfb=3RT2016-1AP01>

Cax online generator

<https://support.automation.siemens.com/WW/CAXorder/default.aspx?lang=en&mlfb=3RT2016-1AP01>

Service&Support (Manuals, Certificates, Characteristics, FAQs,...)

<https://support.industry.siemens.com/cs/ww/en/ps/3RT2016-1AP01>

Image database (product images, 2D dimension drawings, 3D models, device circuit diagrams, EPLAN macros, ...)

[https://www.automation.siemens.com/bilddb/cax\\_de.aspx?mlfb=3RT2016-1AP01&lang=en](https://www.automation.siemens.com/bilddb/cax_de.aspx?mlfb=3RT2016-1AP01&lang=en)

Characteristic: Tripping characteristics, I<sup>t</sup>, Let-through current

<https://support.industry.siemens.com/cs/ww/en/ps/3RT2016-1AP01/char>

Further characteristics (e.g. electrical endurance, switching frequency)

<https://www.automation.siemens.com/bilddb/index.aspx?view=Search&mlfb=3RT2016-1AP01&objecttype=14&gridview=view1>

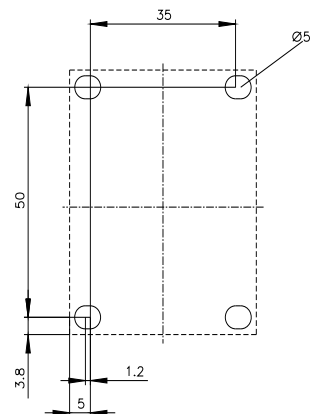
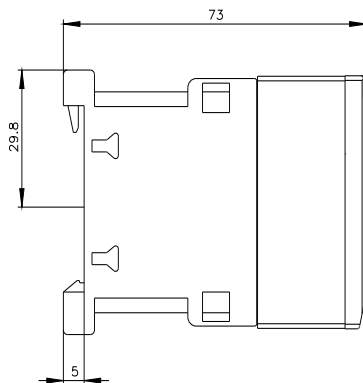
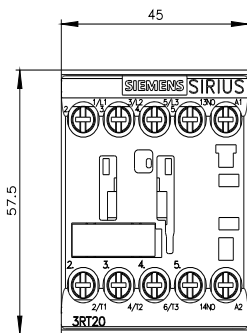

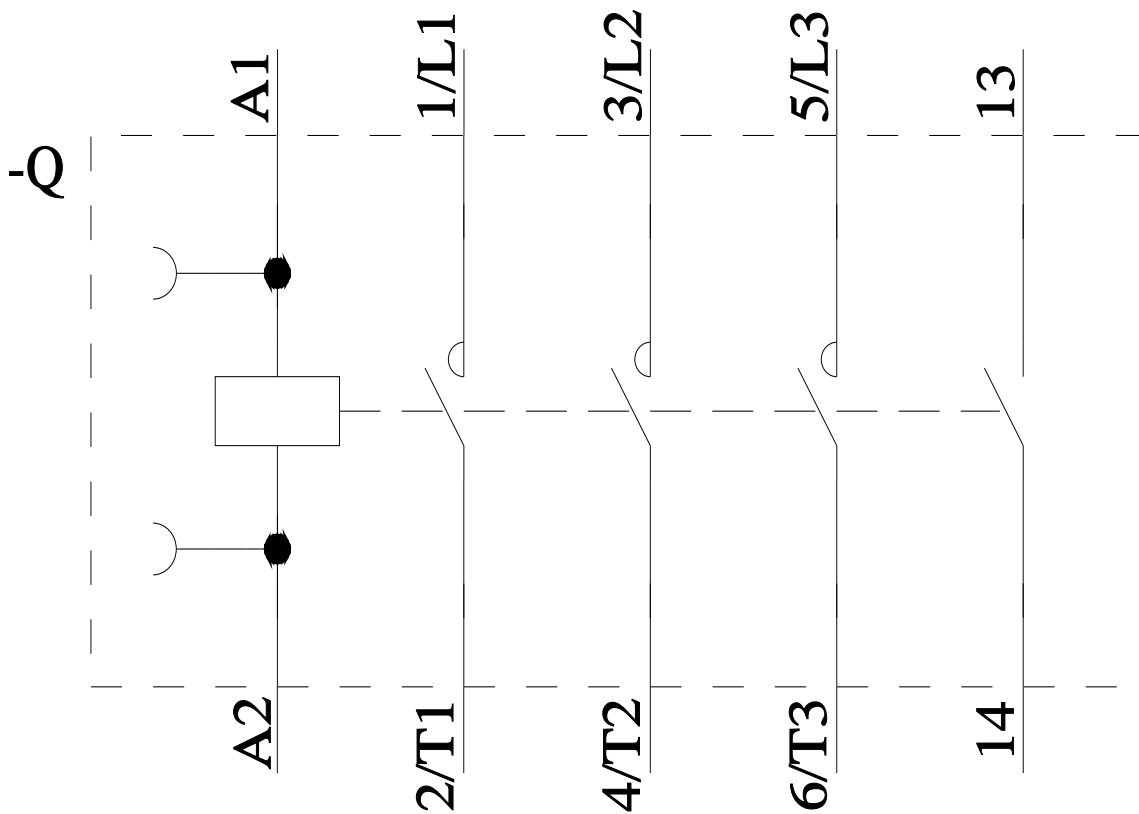

last modified:

11/27/2025