

FASTON FEMM.6.3x0.8
+ COPRIFASTON RPM

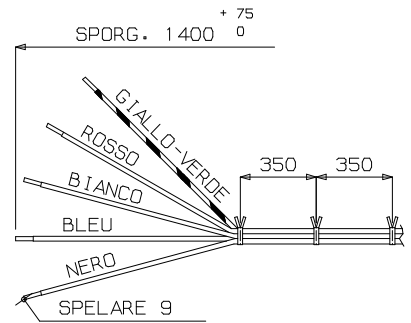
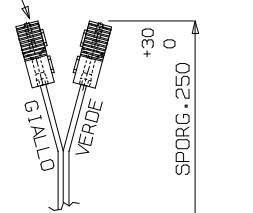

NOTE :

- ANELLO IN GOMMA E IN FERRO
- FORNIRE SEPARATAMENTE CULLA COD.300024.03 E GANCI.

SCHEMA CONNESSIONI

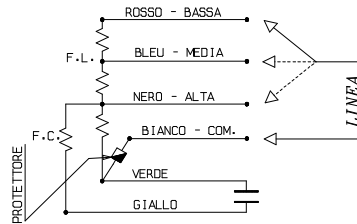

IND	DATA	MODIFICHE	DISEGNATO	CONTROLLATO
4	04/03/08	SOSTITUITO CAPPUCCIO CONDENSATORE CON COPRIFASTON	PADEVANI	
3	26/06/02	TOLTO GOMME CUSCINETTO	ORLANDI	
2	07/11/00	TOLTO COPRIFASTON SU CAVETTI CONDENSATORE	ORLANDI	
1	02/04/96	CAMBIATO PASSACAVO, ERA RETTANGOLARE, TERRA ERA ESTERNA.	BACCAGLINI	
		<p>TIPO MOTORE MONOFASE 1/2 APERTO</p> <p>CARAT. MECCANICHE CUSCINETTI</p> <p>VOLT 220/240 HZ 50 AMP. -</p> <p>WATT - HP 1/5 μF 5 VC 450</p> <p>GIRI - POLI 4 CL. B W VEL. 3</p> <p>SOSTITUISCE PARI NUMERO DEL 06/02/90</p> <p>DATA 02/04/96 SCALA 1:1</p> <p>DISIGNATO BACCAGLINI</p> <p>CONTROLLATO</p> <p>CODICE MOTORE 110153.16</p> <p>CODICE CLIENTE</p>		