

A4D630-AH01-01

AC axial fan - HyBlade

sickle-shaped blades (S series)



ebm-papst Muldingen GmbH & Co. KG

Bachmühle 2 · D-74673 Muldingen

Phone +49 7938 81-0

Fax +49 7938 81-110

info1@de.ebmpapst.com

www.ebmpapst.com

Limited partnership · Headquarters Muldingen

Amtsgericht (court of registration) Stuttgart · HRA 590344

General partner Elektrobau Muldingen GmbH · Headquarters Muldingen

Amtsgericht (court of registration) Stuttgart · HRB 590142

Nominal data

Type	A4D630-AH01-01		
Motor	M4D138-HF		
Phase		3~	3~
Nominal voltage	VAC	400	400
Wiring		Δ	Y
Frequency	Hz	50	50
Method of obtaining data		ml	ml
Valid for approval/standard		CE	CE
Speed (rpm)	min ⁻¹	1310	1000
Power consumption	W	1970	1290
Current draw	A	3.4	2.1
Max. back pressure	Pa	200	115
Max. back pressure	in. wg	0.8	0.46
Min. ambient temperature	°C	-40	-40
Max. ambient temperature	°C	60	60
Starting current	A	14	4.5

ml = Max. load · me = Max. efficiency · fa = Free air · cs = Customer specification · ce = Customer equipment
Subject to change

Data according to Commission Regulation (EU) 327/2011

	Actual	Req. 2015		
01 Overall efficiency η_{es}	%	35.4	35.4	
02 Measurement category		A		
03 Efficiency category		Static		
04 Efficiency grade N		40	40	
05 Variable speed drive		No		
09 Power consumption P_e	kW			1.89
09 Air flow q_v	m ³ /h			12645
09 Pressure increase p_{fs}	Pa			188
10 Speed (rpm) n	min ⁻¹			1335
11 Specific ratio*				1.00

Data obtained at optimum efficiency level.
The ErP data is determined using a motor-impeller combination in a standardized measurement setup.

* Specific ratio = $1 + p_{fs} / 100\,000\text{ Pa}$

LU-124971



Technical description

Weight	19.9 kg
Size	630 mm
Motor size	138
Rotor surface	Cast in aluminum
Terminal box material	PP plastic
Blade material	Sheet aluminum insert, sprayed with PP plastic
Number of blades	5
Blade pitch	-5°
Airflow direction	V
Direction of rotation	Clockwise, viewed toward rotor
Degree of protection	IP54
Insulation class	"F"
Moisture (F) / Environmental (H) protection class	H2
Ambient temperature note	Occasional start-up at temperatures between -40°C and -25°C is permitted. For continuous operation at ambient temperatures below -25°C (such as refrigeration applications), use must be made of a fan design with special low-temperature bearings.
Max. permitted ambient temp. for motor (transport/storage)	+80 °C
Min. permitted ambient temp. for motor (transport/storage)	-40 °C
Installation position	Any
Condensation drainage holes	On rotor and stator sides
Mode	S1
Motor bearing	Ball bearing
Touch current according to IEC 60990 (measuring circuit Fig. 4, TN system)	<= 3.5 mA
Electrical hookup	Terminal box
Motor protection	Thermal overload protector (TOP) with basic insulation
With cable	Axial
Protection class	I (with customer connection of protective earth)
Conformity with standards	EN 60034-1 (2010); CE
Approval	VDE; EAC

AC axial fan - HyBlade

sickle-shaped blades (S series)

Product drawing

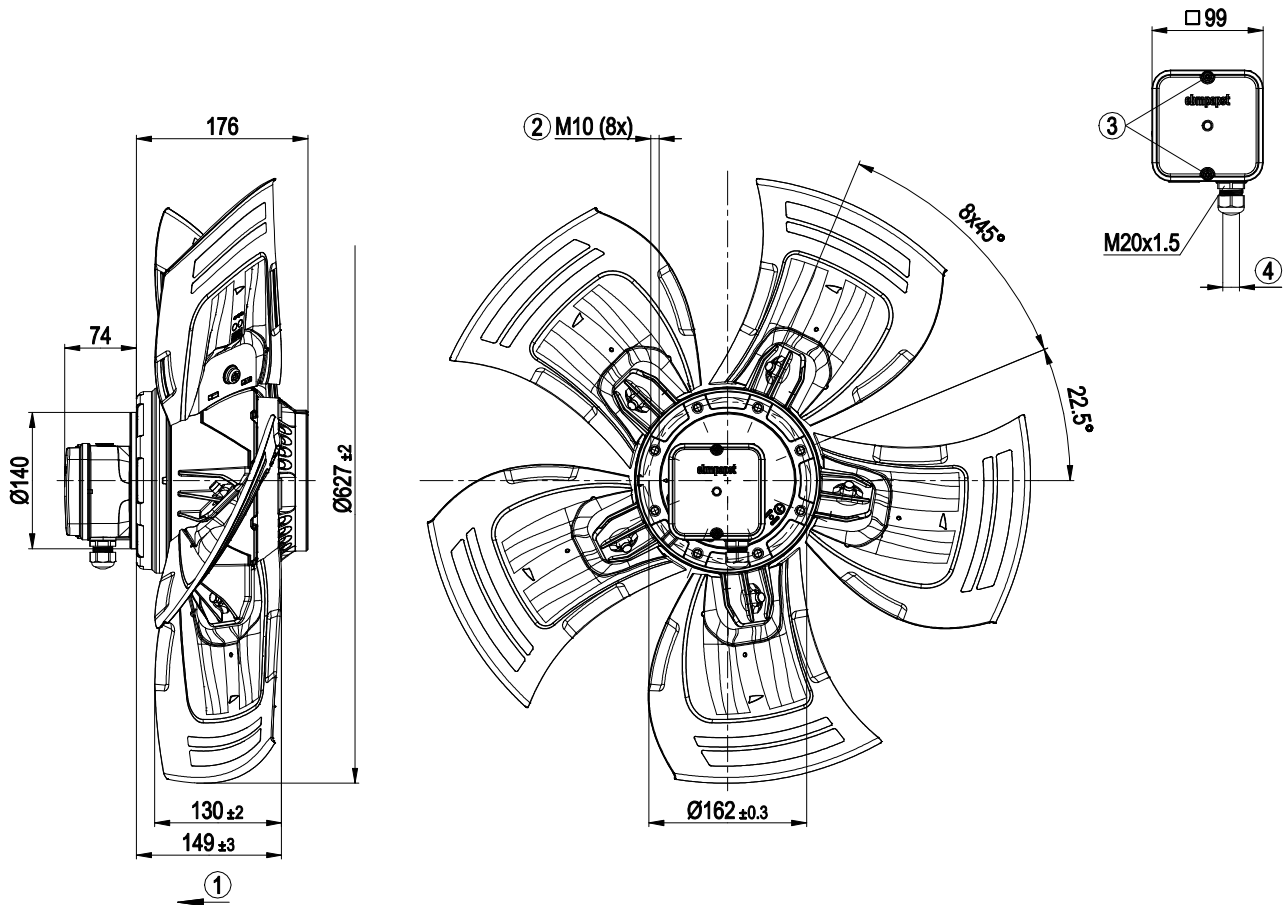

1	Direction of air flow "V"
2	Max. clearance for screw 18 mm
3	Tightening torque 1.5 ± 0.2 Nm
4	Cable diameter min. 7 mm, max. 14 mm, tightening torque 2 ± 0.3 Nm

AC axial fan - HyBlade

sickle-shaped blades (S series)

Connection diagram

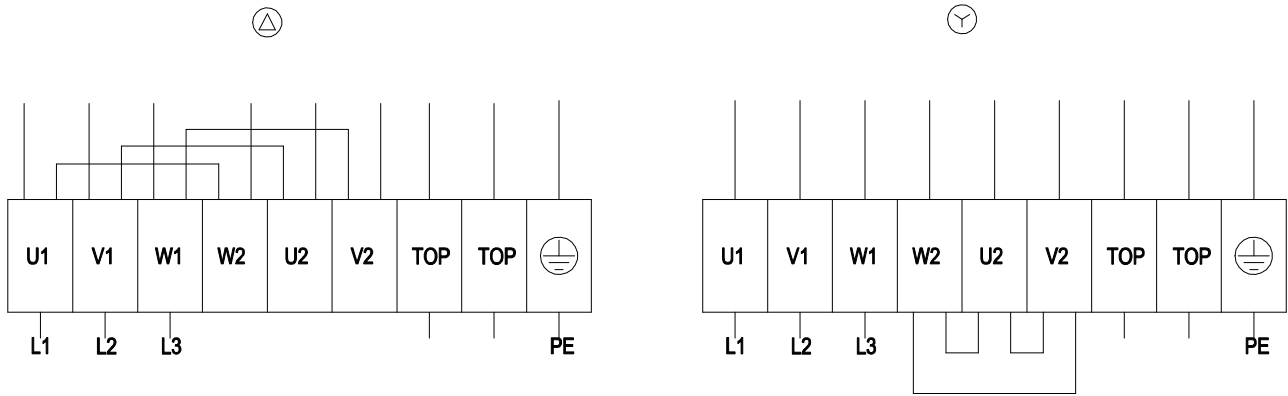

Δ	Delta connection	Y	Star connection	L1	= U1 = black
L2	= V1 = blue	L3	= W1 = brown	W2	yellow
U2	green	V2	white	TOP	2x gray
PE	green/yellow				



Curves: Air performance 50 Hz

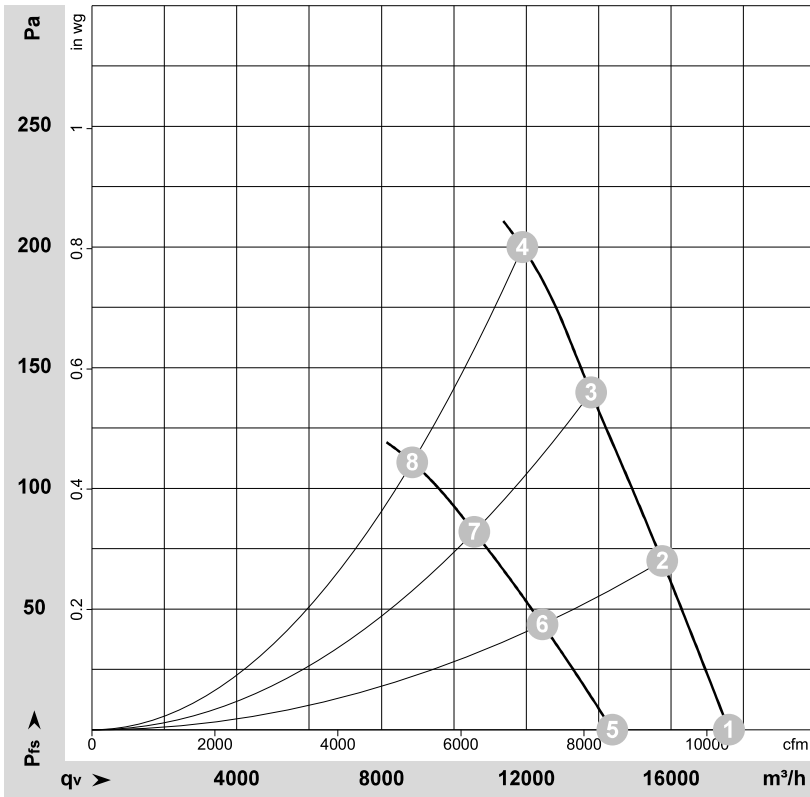

$\rho = 1.15 \text{ kg/m}^3 \pm 2 \%$

Measurement: LU-134384-1
Measurement: LU-109489-1

Air performance measured according to ISO 5801 installation category A. For detailed information on the measurement setup, contact ebm-papst. Intake sound level: Sound power level according to ISO 13347 / sound pressure level measured at 1 m distance from fan axis. The values given are valid under the specified measuring conditions and may vary due to conditions of installation. For deviations from the standard configuration, the parameters have to be checked on the installed unit.

Measured values

	Wired	U	f	n	P _e	I	LpA _{in}	LwA _{in}	LwA _{out}	q _v	p _{fs}	q _v	p _{fs}
		V	Hz	min ⁻¹	W	A	dB(A)	dB(A)	dB(A)	m ³ /h	Pa	cfm	in. wg
1	Δ	400	50	1380	1483	2.83	70	77	77	17595	0	10355	0.00
2	Δ	400	50	1360	1676	3.07	69	76	76	15755	70	9270	0.28
3	Δ	400	50	1335	1854	3.33	69	75	75	13790	140	8115	0.56
4	Δ	400	50	1310	1970	3.40	71	78	77	11890	200	7000	0.80
5	Y	400	50	1125	1079	1.80	65	72	72	14375	0	8460	0.00
6	Y	400	50	1075	1175	1.96	63	70	70	12445	44	7325	0.18
7	Y	400	50	1035	1237	2.08	62	68	69	10560	82	6215	0.33
8	Y	400	50	1000	1290	2.10	63	70	70	8850	111	5210	0.45

Wired = Wiring · U = Voltage · f = Frequency · n = Speed (rpm) · P_e = Power consumption · I = Current draw · LpA_{in} = Sound pressure level intake side · LwA_{in} = Sound power level intake side
LwA_{out} = Sound power level outlet side · q_v = Air flow · p_{fs} = Pressure increase

