

**ebm-papst Mulfingen GmbH & Co. KG**

Bachmühle 2 · D-74673 Mulfingen

Phone +49 7938 81-0

Fax +49 7938 81-110

info1@de.ebmpapst.com

www.ebmpapst.com

Limited partnership · Headquarters Mulfingen

Amtsgericht (court of registration) Stuttgart · HRA 590344

General partner Elektrobau Mulfingen GmbH · Headquarters Mulfingen

Amtsgericht (court of registration) Stuttgart · HRB 590142

**Nominal data**

Type	A6D630-AN01-01						
Motor	M6D110-GF						
Phase		3~	3~	3~	3~	3~	3~
Nominal voltage	VAC	400	400	400	400	480	480
Wiring		Δ	Y	Δ	Y	Δ	Y
Frequency	Hz	50	50	60	60	60	60
Method of obtaining data		ml	ml	ml	ml	ml	ml
Valid for approval/standard		CE	CE	CE	CE	CE	CE
Speed (rpm)	min <sup>-1</sup>	890	690	1010	700	1070	820
Power consumption	W	600	400	730	430	810	550
Current draw	A	1.2	0.68	1.29	0.8	1.35	0.8
Max. back pressure	Pa	105	56	50	26	55	35
Max. back pressure	in. wg	0.42	0.22	0.2	0.1	0.22	0.14
Min. ambient temperature	°C	-40	-40	-40	-40	-40	-40
Max. ambient temperature	°C	65	65	60	60	55	55
Starting current	A	4	1.33	3.5	1.17		

ml = Max. load · me = Max. efficiency · fa = Free air · cs = Customer specification · ce = Customer equipment  
Subject to change

**Data according to Commission Regulation (EU) 327/2011 (EN 17166)**

	Actual	Req. 2015				
01 Overall efficiency $\eta_{es}$	%	34.4	32.2	09 Power consumption $P_e$	kW	0.58
02 Measurement category		A		09 Air flow $q_v$	m <sup>3</sup> /h	7325
03 Efficiency category		Static		09 Pressure increase $p_{fs}$	Pa	99
04 Efficiency grade N		42.2	40	10 Speed (rpm) n	min <sup>-1</sup>	890
05 Variable speed drive		No		11 Specific ratio*		1.00

Data obtained at optimum efficiency level.

\* Specific ratio =  $1 + p_{fs} / 100\,000\text{ Pa}$ 

LU-199334

The efficiency values displayed for achieving conformity with the Ecodesign Regulation EU 327/2011 has been reached with defined air duct components (e.g. inlet rings).  
The dimensions must be requested from ebm-papst. If other air conduction geometries are used on the installation side, the ebm-papst evaluation loses its validity/the conformity must be confirmed again.  
The product does not fall within the scope of Regulation (EU) 2019/1781 due to the exception specified in Article 2 (2a) (motors completely integrated into a product).



## Technical description

<b>Weight</b>	9.9 kg
<b>Size</b>	630 mm
<b>Motor size</b>	110
<b>Rotor surface</b>	Painted black
<b>Terminal box material</b>	PP plastic
<b>Blade material</b>	Press-fitted sheet steel blank, sprayed with PP plastic
<b>Number of blades</b>	5
<b>Airflow direction</b>	V
<b>Direction of rotation</b>	Counterclockwise, viewed toward rotor
<b>Degree of protection</b>	IP54
<b>Insulation class</b>	"F"
<b>Moisture (F) / Environmental (H) protection class</b>	H2
<b>Ambient temperature note</b>	Occasional start-up at temperatures between -40°C and -25°C is permitted. For continuous operation at ambient temperatures below -25°C (such as refrigeration applications), use must be made of a fan design with special low-temperature bearings.
<b>Max. permitted ambient temp. for motor (transport/storage)</b>	+80 °C
<b>Min. permitted ambient temp. for motor (transport/storage)</b>	-40 °C
<b>Installation position</b>	Shaft horizontal or rotor on bottom; rotor on top on request
<b>Condensation drainage holes</b>	On rotor side
<b>Mode</b>	S1
<b>Motor bearing</b>	Ball bearing
<b>Touch current according to IEC 60990 (measuring circuit Fig. 4, TN system)</b>	<= 3.5 mA
<b>Electrical hookup</b>	Terminal box
<b>Motor protection</b>	Thermal overload protector (TOP) with basic insulation
<b>With cable</b>	Axial
<b>Protection class</b>	I (with customer connection of protective earth)
<b>Conformity with standards</b>	EN 60034-1 (2010); CE; UKCA
<b>Approval</b>	VDE; CCC; EAC

## Product drawing

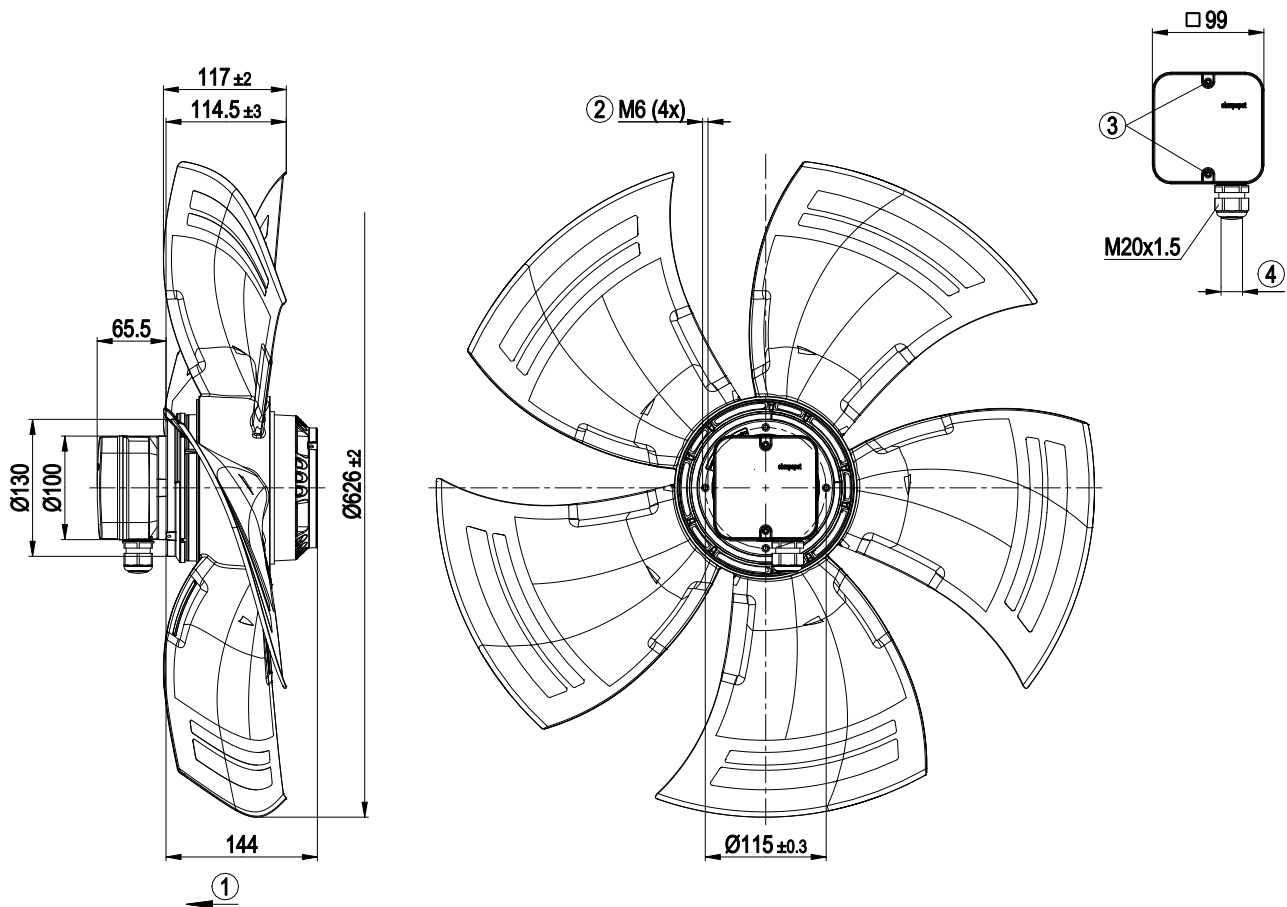

1	Direction of air flow "V"
2	Max. clearance for screw 12 mm
3	Tightening torque $1.5 \pm 0.2$ Nm
4	Cable diameter min. 6 mm, max. 12 mm, tightening torque $2 \pm 0.3$ Nm

## Connection diagram

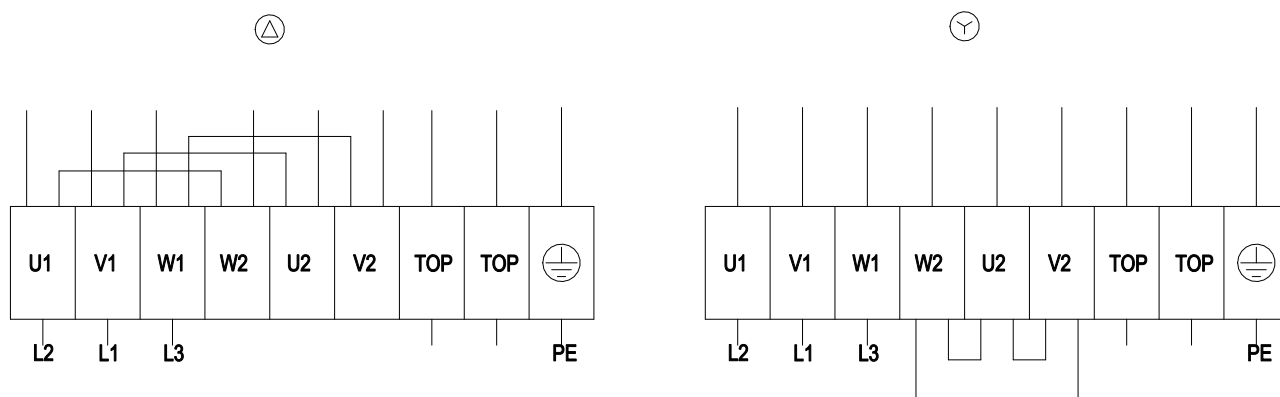

Δ	Delta connection	Y	Star connection	L1	= V1 = blue
L2	= U1 = black	L3	= W1 = brown	W2	yellow
U2	green	V2	white	TOP	2x gray
PE	green/yellow				