

EMT6144Z

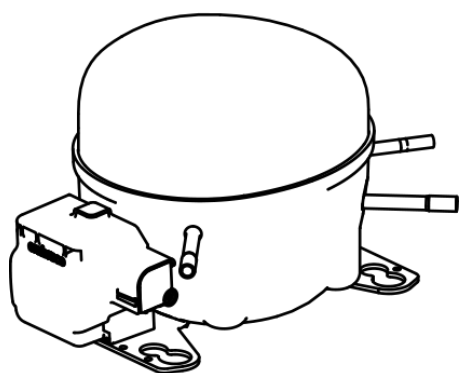

ENGINEERING CODE
513306218

REFRIGERANT
R-134a

POWER SUPPLY
220-240 V 50 Hz

APPLICATION
HBP

MOTOR TYPE
CSIR

STANDARD
EN12900

COOLING CAPACITY
508 W

EFFICIENCY
2.44 W/W



DATA

GENERAL DATA

Model	EMT6144Z
Type	Hermetic Reciprocating
Technology	ON/OFF
Compressor Application	HBP
Expansion Device	Capillary Tube or Expansion Valve
Compressor Cooling	Fan/220
HP	1/5
Starting Torque	HST
Plant	BRAZIL

ELECTRICAL DATA

Start Winding Resistance	21.3 Ω at 25°C
Run Winding Resistance	12.95 Ω at 25°C

MECHANICAL DATA

Displacement	5.19 cm ³
Oil Charge	180 ml
Oil Type	ESTER
Oil Viscosity	ISO22
Weight	7.7 Kg

ELECTRICAL COMPONENTS

Start Capacitor	43-53 µf/330 V
CSR CSIR BOX	No
Starting Device Type	RELAY
Overload Protection	T0827/G6

EXTERNAL CHARACTERISTICS

Base Plate	SMALL EUEM
Tray Holder	YES

Connector	Internal Diameter	Shape	Material
Suction	6.1 mm	SLANTED 42° UP + 45° TO BACK	COPPER
Discharge	4.94 mm	SLANTED PARALLET BP+24°TO BACK	COPPER
Process	6.1 mm	SLANTED 45° UP + 45° TO BACK	COPPER

PERFORMANCE

TESTED CONDITIONS

Tested Refrigerant	R-134a
Tested Application	HBP
Tested Standard	EN12900
Tested Cooling	Fan
Tested Voltage	220 V
Tested Frequency	50 Hz
Max Refrigerant Charge	250 g
Refrigerant Temperature	Dew

RATED POINTS

Condensing Temperature °C	Evaporating Temperature °C	Cooling Capacity W	Efficiency W/W	Power Consumption W	Current A	Gas Flow Rate kg/h
50	5	508	2.44	208	-	12.75

Test Condition: Subcooling 0 K, Return Gas 20 °C. Data are an indication of performance based simulation.

PERFORMANCE CURVE**Condensing Temperature 35°C**

Evaporating Temperature °C	Cooling Capacity W	Efficiency W/W	Power Consumption W	Current A	Gas Flow Rate kg/h
-15	267	2.07	129	-	5.64
-10	336	2.38	141	-	7.14
-5	417	2.70	154	-	8.91
0	511	3.08	166	-	10.99
5	620	3.55	174	-	13.43
10	744	4.20	177	-	16.27

Test Condition: Subcooling 0 K, Return Gas 20 °C. Data are an indication of performance based simulation.

PERFORMANCE CURVE**Condensing Temperature 45°C**

Evaporating Temperature °C	Cooling Capacity W	Efficiency W/W	Power Consumption W	Current A	Gas Flow Rate kg/h
-15	230	1.63	141	-	5.33
-10	291	1.90	153	-	6.79
-5	363	2.16	168	-	8.52
0	448	2.42	185	-	10.58
5	546	2.72	200	-	12.99
10	657	3.09	213	-	15.81

Test Condition: Subcooling 0 K, Return Gas 20 °C. Data are an indication of performance based simulation.

PERFORMANCE CURVE**Condensing Temperature 55°C**

Evaporating Temperature °C	Cooling Capacity W	Efficiency W/W	Power Consumption W	Current A	Gas Flow Rate kg/h
-10	247	1.54	160	-	6.41
-5	310	1.78	175	-	8.10
0	384	1.99	193	-	10.11
5	470	2.21	213	-	12.49
10	569	2.46	232	-	15.27

Test Condition: Subcooling 0 K, Return Gas 20 °C. Data are an indication of performance based simulation.

ENVELOPE

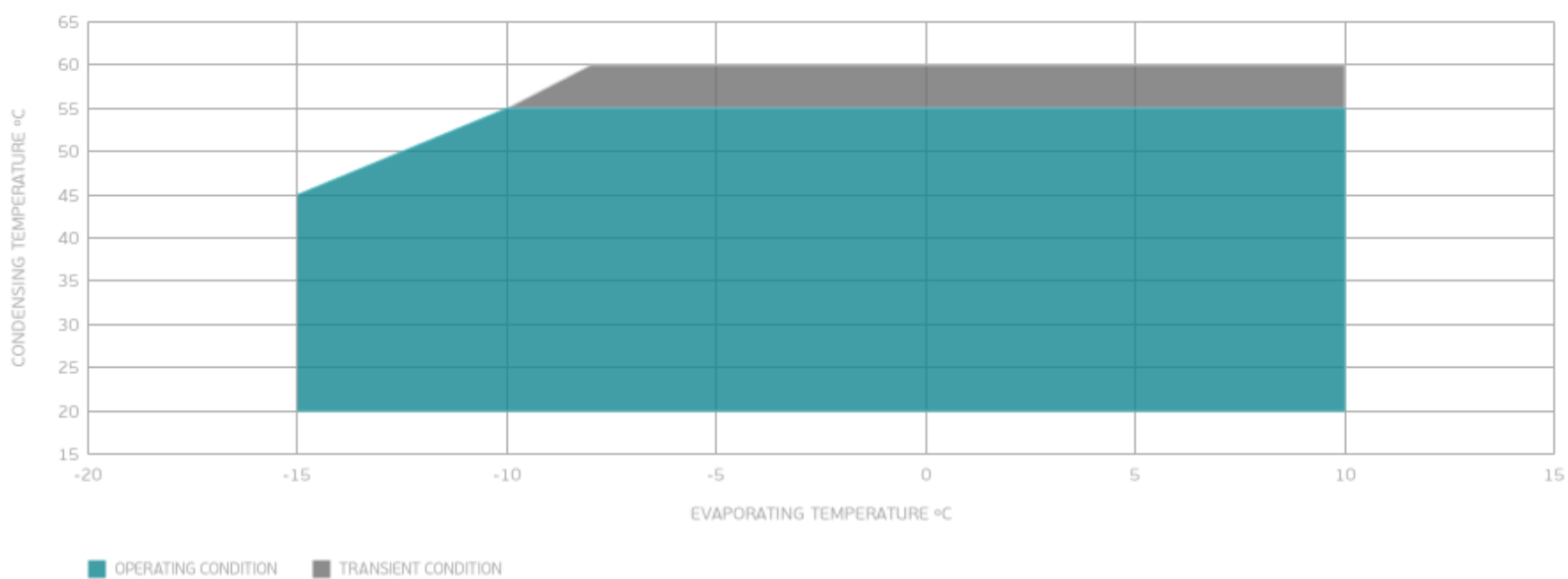

EXTERNAL DIMENSIONS

