

EMT6170Z

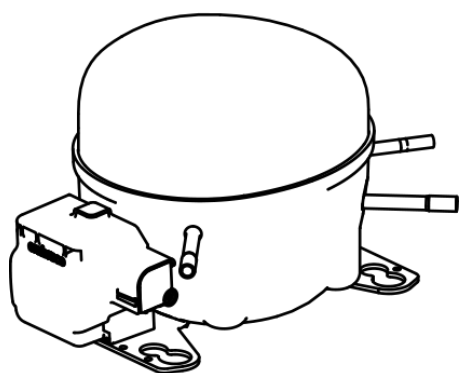

ENGINEERING CODE
194RA67

REFRIGERANT
R-134a

POWER SUPPLY
220-240 V 50 Hz

APPLICATION
LBP

MOTOR TYPE
CSIR

STANDARD
EN12900

COOLING CAPACITY
713 W

EFFICIENCY
2.11 W/W

DATA

GENERAL DATA

Model	EMT6170Z
Type	Hermetic Reciprocating
Technology	ON/OFF
Compressor Application	LBP
Expansion Device	Capillary Tube or Expansion Valve
Compressor Cooling	Fan/220
HP	1/3-
Starting Torque	HST
Plant	ITALY

ELECTRICAL DATA

Start Winding Resistance	null
Run Winding Resistance	null
Locked Rotor Amperage (LRA) 50Hz	10.4 A
Rated Load Amperage (LMBP) at 50 Hz	1.9 A

MECHANICAL DATA

Displacement	7.69 cm ³
Oil Charge	180 ml
Oil Type	ESTER
Oil Viscosity	ISO22
Weight	7.8 Kg

ELECTRICAL COMPONENTS

Start Capacitor	53-64 µf/330 V
CSR CSIR BOX	No
Starting Device Type	RELAY
Overload Protection	T0318/G6

EXTERNAL CHARACTERISTICS

Base Plate	SMALL
Tray Holder	YES

Connector	Internal Diameter	Shape	Material
Suction	6.1 mm	SLANTED 42°	COPPER
Discharge	4.86 mm	STRAIGHT	COPPER
Process	6.1 mm	SLANTED 42°	COPPER

PERFORMANCE

TESTED CONDITIONS

Tested Refrigerant	R-134a
Tested Application	HBP
Tested Standard	EN12900
Tested Cooling	Fan
Tested Voltage	220 V
Tested Frequency	50 Hz
Max Refrigerant Charge	250 g
Refrigerant Temperature	Dew

RATED POINTS

Condensing Temperature °C	Evaporating Temperature °C	Cooling Capacity W	Efficiency W/W	Power Consumption W	Current A	Gas Flow Rate kg/h
50	5	713	2.11	338	-	17.88

Test Condition: Subcooling 0 K, Return Gas 20 °C. Data are an indication of performance based simulation.

PERFORMANCE CURVE**Condensing Temperature 35°C**

Evaporating Temperature °C	Cooling Capacity W	Efficiency W/W	Power Consumption W	Current A	Gas Flow Rate kg/h
-15	379	1.90	200	-	8.02
-10	475	2.15	222	-	10.11
-5	588	2.37	248	-	12.56
0	716	2.61	275	-	15.41
5	862	2.87	300	-	18.67
10	1024	3.19	321	-	22.39

Test Condition: Subcooling 0 K, Return Gas 20 °C. Data are an indication of performance based simulation.

PERFORMANCE CURVE**Condensing Temperature 45°C**

Evaporating Temperature °C	Cooling Capacity W	Efficiency W/W	Power Consumption W	Current A	Gas Flow Rate kg/h
-15	330	1.53	216	-	7.66
-10	417	1.76	237	-	9.73
-5	518	1.96	265	-	12.16
0	634	2.13	297	-	14.96
5	763	2.30	331	-	18.18
10	908	2.49	364	-	21.83

Test Condition: Subcooling 0 K, Return Gas 20 °C. Data are an indication of performance based simulation.

PERFORMANCE CURVE**Condensing Temperature 55°C**

Evaporating Temperature °C	Cooling Capacity W	Efficiency W/W	Power Consumption W	Current A	Gas Flow Rate kg/h
-10	354	1.46	242	-	9.19
-5	444	1.66	267	-	11.59
0	546	1.82	300	-	14.36
5	661	1.95	338	-	17.53
10	788	2.08	378	-	21.13

Test Condition: Subcooling 0 K, Return Gas 20 °C. Data are an indication of performance based simulation.

ENVELOPE

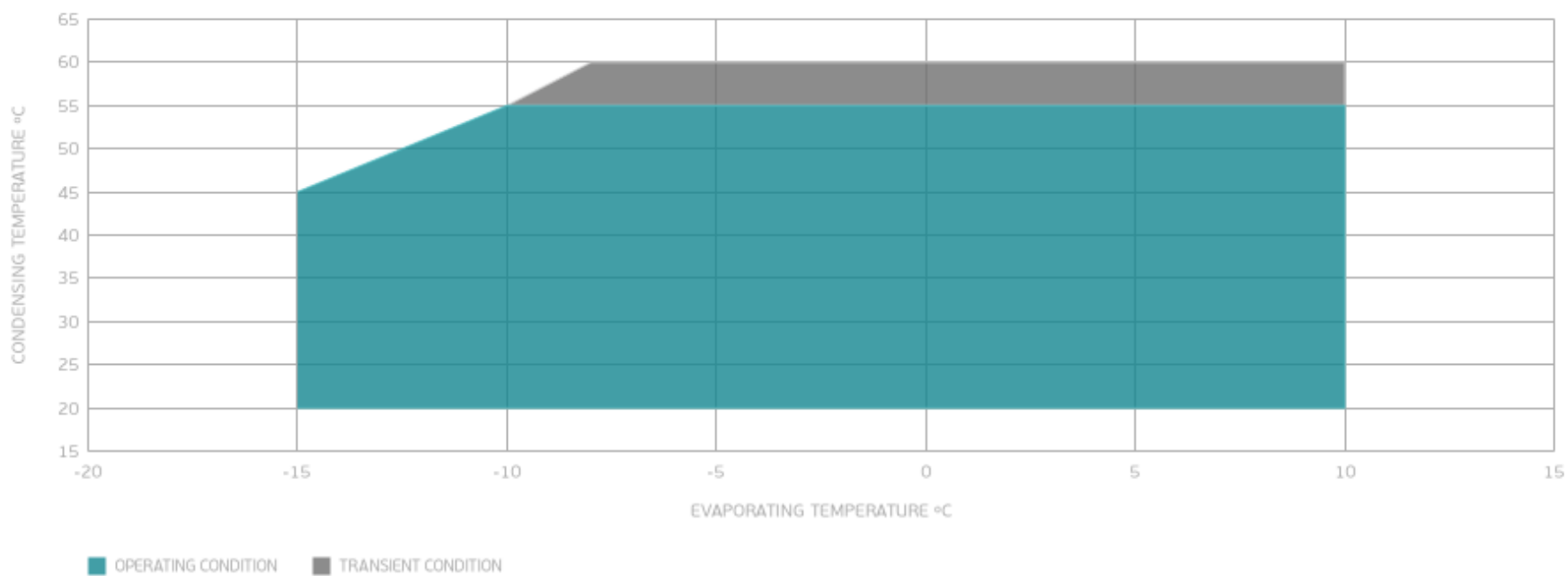

EXTERNAL DIMENSIONS

