

EMT50HDP

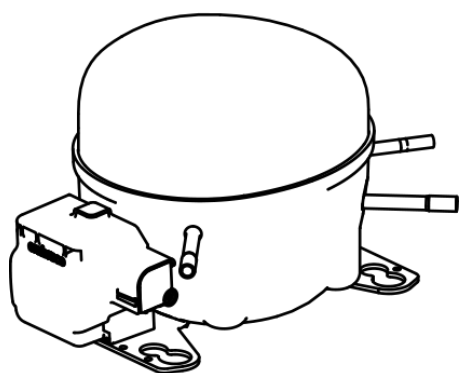

ENGINEERING CODE
194MA67

REFRIGERANT
R-134a

POWER SUPPLY
220-240 V 50 Hz

APPLICATION
HBP

MOTOR TYPE
RSIR

STANDARD
EN12900

COOLING CAPACITY
421 W

EFFICIENCY
2.5 W/W

DATA

GENERAL DATA

Model	EMT50HDP
Type	Hermetic Reciprocating
Technology	ON/OFF
Compressor Application	HBP
Expansion Device	Capillary Tube
Compressor Cooling	Static/220
Starting Torque	LST
Plant	ITALY

ELECTRICAL DATA

Start Winding Resistance	33.6 Ω at 25°C
Run Winding Resistance	18.7 Ω at 25°C
Locked Rotor Amperage (LRA) 50Hz	6.4 A

MECHANICAL DATA

Displacement	4.5 cm ³
Oil Charge	180 ml
Oil Type	ESTER
Oil Viscosity	ISO22
Weight	7.7 Kg

ELECTRICAL COMPONENTS

CSR CSIR BOX	No
Starting Device Type	PTC
Overload Protection	T0521/26

EXTERNAL CHARACTERISTICS

Base Plate	SMALL
Tray Holder	YES

Connector	Internal Diameter	Shape	Material
Suction	6.1 mm	SLANTED 42°	COPPER
Discharge	4.86 mm	STRAIGHT	COPPER
Process	6.1 mm	SLANTED 42°	COPPER

PERFORMANCE

TESTED CONDITIONS

Tested Refrigerant	R-134a
Tested Application	HBP
Tested Standard	EN12900
Tested Cooling	Static
Tested Voltage	220 V
Tested Frequency	50 Hz
Max Refrigerant Charge	250 g
Refrigerant Temperature	Dew

RATED POINTS

Condensing Temperature °C	Evaporating Temperature °C	Cooling Capacity W	Efficiency W/W	Power Consumption W	Current A	Gas Flow Rate kg/h
50	5	421	2.5	168	-	10.55

Test Condition: Subcooling 0 K, Return Gas 20 °C. Data are an indication of performance based simulation.

PERFORMANCE CURVE**Condensing Temperature 35°C**

Evaporating Temperature °C	Cooling Capacity W	Efficiency W/W	Power Consumption W	Current A	Gas Flow Rate kg/h
-15	218	2.18	100	-	4.61
-10	278	2.53	110	-	5.92
-5	350	2.90	120	-	7.47
0	432	3.34	129	-	9.28
5	524	3.87	136	-	11.35
10	627	4.56	137	-	13.70

Test Condition: Subcooling 0 K, Return Gas 20 °C. Data are an indication of performance based simulation.

PERFORMANCE CURVE**Condensing Temperature 45°C**

Evaporating Temperature °C	Cooling Capacity W	Efficiency W/W	Power Consumption W	Current A	Gas Flow Rate kg/h
-15	186	1.69	110	-	4.31
-10	238	1.97	121	-	5.55
-5	301	2.24	134	-	7.05
0	373	2.53	148	-	8.81
5	455	2.84	160	-	10.83
10	547	3.22	170	-	13.14

Test Condition: Subcooling 0 K, Return Gas 20 °C. Data are an indication of performance based simulation.

PERFORMANCE CURVE**Condensing Temperature 55°C**

Evaporating Temperature °C	Cooling Capacity W	Efficiency W/W	Power Consumption W	Current A	Gas Flow Rate kg/h
-10	201	1.56	129	-	5.21
-5	254	1.78	142	-	6.62
0	316	2.00	158	-	8.30
5	387	2.22	174	-	10.26
10	466	2.45	190	-	12.51

Test Condition: Subcooling 0 K, Return Gas 20 °C. Data are an indication of performance based simulation.

ENVELOPE

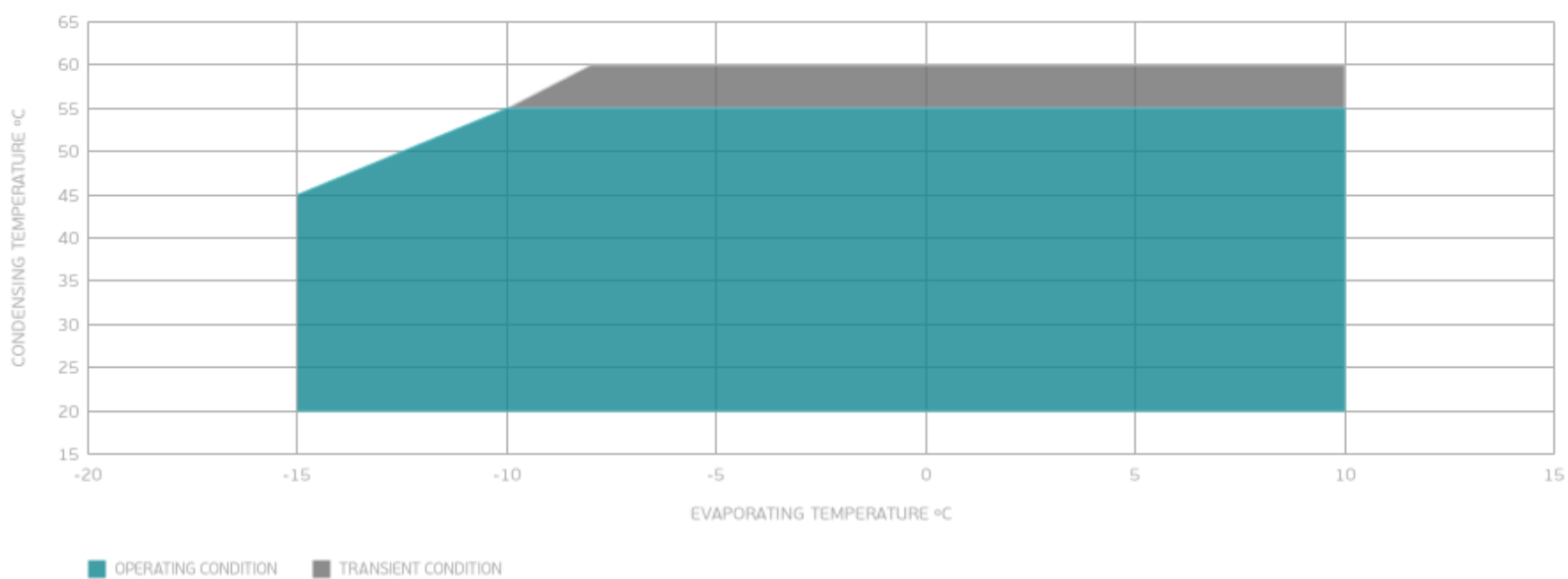

EXTERNAL DIMENSIONS

